



Queensland University of Technology
Facilities Management

LANDSCAPE DESIGN
STANDARDS & GUIDELINES
SECTION 39

Table of Contents

ABOUT THIS MANUAL	3
DEFINITIONS.....	4
1 INTENT	6
2 LANDSCAPE TYPES	7
3 SOILS.....	8
NUTRIENT AVAILABILITY THROUGH PH	8
ALTERING SOIL PH	10
4 TURF	12
CUTTING HEIGHTS	14
TURF GRADES	15
LEVEL 1 - HIGH PROFILE LAWNS	16
LEVEL 2 - MEDIUM PROFILE LAWN	17
LEVEL 3 – BUSH OR ENVIRONMENTAL AREAS	18
FERTILISERS	19
FERTILISER SPREADER CALIBRATION	20
FERTILISER APPLICATION	20
WEED, PEST AND DISEASE CONTROL	21
5 GARDENS.....	24
GARDEN CATEGORIES	24
LEVEL G1 – HIGH PROFILE GARDENS	24
LEVEL G2 - MEDIUM PROFILE GARDENS	26
LEVEL G3 - BUSH OR ENVIRONMENTAL AREAS	28
MULCHING GARDENS	31
PLANTING DETAILS	32
PRUNING SHRUBS	33
TRANSPLANTING SHRUBS	36
6 TREES	37
MULCHING TREES	37
GENERAL MAINTENANCE	38
FERTILISING TREES.....	38
STAKING TREES	39
PRUNING TREES.....	40
7 SURFACES	43
8 RUBBISH AND DEBRIS.....	44
9 RESTRICTIONS	44

About this Manual

The information contained in each section of this “Standards Manual” is presented in three distinct ways for easy reference.

1. General reference material will be presented as normal paragraphed text
2.
 - Important points will be presented with a bullet and will be indented
3.  *The actual work standard will be listed after an arrow. All Standards will be in italics*

Definitions

In these guidelines, unless otherwise stated the following definitions will prevail:

Authorised Works

Any work as authorised and required to be carried out under the direction of the Grounds Supervisor.

Campus

Areas within the designated property boundaries of the University, or land under the control of the University, including free standing buildings.

Debris

Any displaced plant material (such as fronds, branches, clippings, mulch or flowers) that interferes with the intended aesthetics of the area.

Edges

Any interface within a garden bed, turf area, paved or hard surface area.

Pruning/Trimming

The removal of unwanted plant growth using motorised or manual equipment. This will include the shaping of trees, shrubs, grasses and other ornamentals, particularly around hard surfaces, lights, fixtures and buildings.

Equipment

Powered or non-powered tools and machinery used for grounds maintenance activities.

Garden Beds

Any identified formal or informal planted or mulched area.

Rubbish

Any waste material including paper, cans, bottles, food scraps or other unwanted refuse.

Mulch

A protective covering of organic or inorganic material laid over the soil around plants to prevent erosion and retain moisture. No tub grindings, palm crowns or tip mulch will be used on any campus

Needles

Any hypodermic needles need to be handled in accordance with University procedure and notification directed to the Grounds Foreperson or Health and Safety for appropriate action.

Weeds

Plants growing in an area set aside for other plants.

Weed Control

The removal or treatment of weeds within a designated area. May include physical or chemical control methods.

Tree protection zone

This is a defined area of ground within which a tree grows and needs to be protected from any damage to its root zone or canopy

1 Intent

The purpose of these guidelines is to provide landscape maintenance staff (both internal and external) with material which informs them of the standard of work required and to set a benchmark on which the quality and frequency of individual landscape maintenance will be assessed. It is anticipated that this document will require updating every 2 - 3 years to accommodate changes in areas, QUT policy and improved work practices.

The information has been put together from material developed by the University, standard horticultural practices, industry standards and guidelines provided by the Grounds Supervisor. In the event of any inconsistencies the Grounds Supervisor should be contacted for clarification.

The purpose of having landscaped areas is to provide a number of benefits:

1. Provide cool relief from glare and heat generated by hard surfaces
2. Provide colour and contrast from buildings and hard surfaces;
3. Provide areas where people can sit, relax and refocus; and
4. Provide resilient surfaces for increased pedestrian function and activity
5. A basic planting theme of canopy trees, under pruned to allow clear head room and access for service and maintenance vehicles, and shrubs and ground covers pruned to maintain views and ensure safety is the primary principle of the University landscape.

Maintenance and presentation standards will be monitored and verified through regular inspections by managers and supervisors with the responsibility for the presentation of the campus environment.

↓ The grounds person assigned responsibility for a defined area is to develop his/her own work programmes and schedule of work. Work programs will be influenced by special requests on Work Orders provided by the Grounds Supervisor and the Facilities help desk. Requests are required to be completed within a specified time frame which will be considerate of the quantum of work to be achieved.

Compromise will always be a key issue in Grounds Maintenance. Understanding that we need to adapt and fine tune our efforts for different situations, rather than apply a general rule of action, must be the thinking at the front of grounds maintenance.

2 Landscape types

Primary or High Profile Areas: More conspicuous, aesthetically pleasing landscaped areas, requiring high levels of maintenance, often used as entry statements and functional areas.

Gardens Point: Due to the location of this campus - adjacent to the Botanic Gardens, Parliament House, the city centre, the river and Goodwill Bridge access, the whole of campus it is considered high profile.

Kelvin Grove: A to C blocks, the Quad courtyard, P block, CIP, SLSC, IHBI, the Ring Rd and Herston Rd entries, sports field and Pavilion and other sites as determined from time to time by the Grounds Supervisor.

Carseldine: Central courtyard, Beams Rd entry (to C block), Dorville Rd entry (10m laterally), main sports field.

Secondary or Medium Profile Areas: Less conspicuous landscape areas designed to enhance building surrounds but not generally used as functional areas.

Kelvin Grove: All areas other than identified high profile or environmental areas.

Carseldine: C block entry to Dorville Rd entry (open woodlands), grassed area south of E block to the car parks and west of L block to the entry path from the car parks, all car parks, the CCC precinct (10m from the perimeter fence and the car park), the G block compound, the secondary sports fields and all the surrounds.

Bush landscape or environmental areas: undeveloped or natural vegetation areas.

Kelvin Grove: Planted and mulched areas which form a barrier between adjoining properties; any undeveloped parts of the Urban Village

Carseldine: The area east of A and L blocks to the ring road and south from the C block entry rd to the car parks (excluding the CCC precinct), south of the car parks from Dorville Rd to the railway lines and Cabbage Tree Creek.

3 Soils

There are a large number of factors that should be considered when maintaining good soils. These factors include;

- formation
- colour
- texture
- structure
- chemistry

As there are a large number of very good publications available on soils this section of the manual will only deal with soil pH, its effect on plants in relation to nutrient availability and how to alter pH levels.

Nutrient Availability through pH

Below is a chart illustrating the availability of nutrients at different pH levels

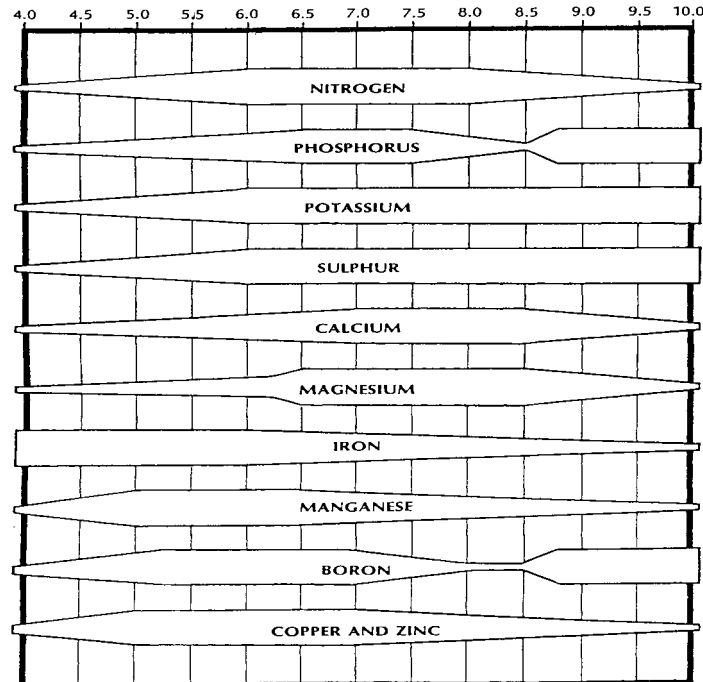

As this diagram illustrates soil pH will directly effect the nutrients available to plants.

It is important to determine what the soil pH is in various gardens within a site and from area to area.

Factors which can cause changing of pH include

- water
- fertilisers
- mushroom compost
- mulches

Soil samples need to be representative of the area to be tested. To collect representative samples from gardens or turf follow these steps.

1. Take six to eight samples from the top 100mm of soil. These samples only need to be equivalent to a desert spoon each.
2. Thoroughly mix the samples together.
3. Take enough soil from the mixed quantity that will allow you to make a test. This may be enough to cover a 50c piece if you are using the CSIRO test kit or may be 25mm in the bottom of a sterile container if testing with a pH Pen.
4. Follow the instructions of the relevant test method to obtain the result. Keep records of soil pH for specific garden beds only. (eg Hibiscus)

Soil pH test results should be kept for future reference. Test results could also be placed on a map of the area so that a 'soil pH map' can be built up of the site.

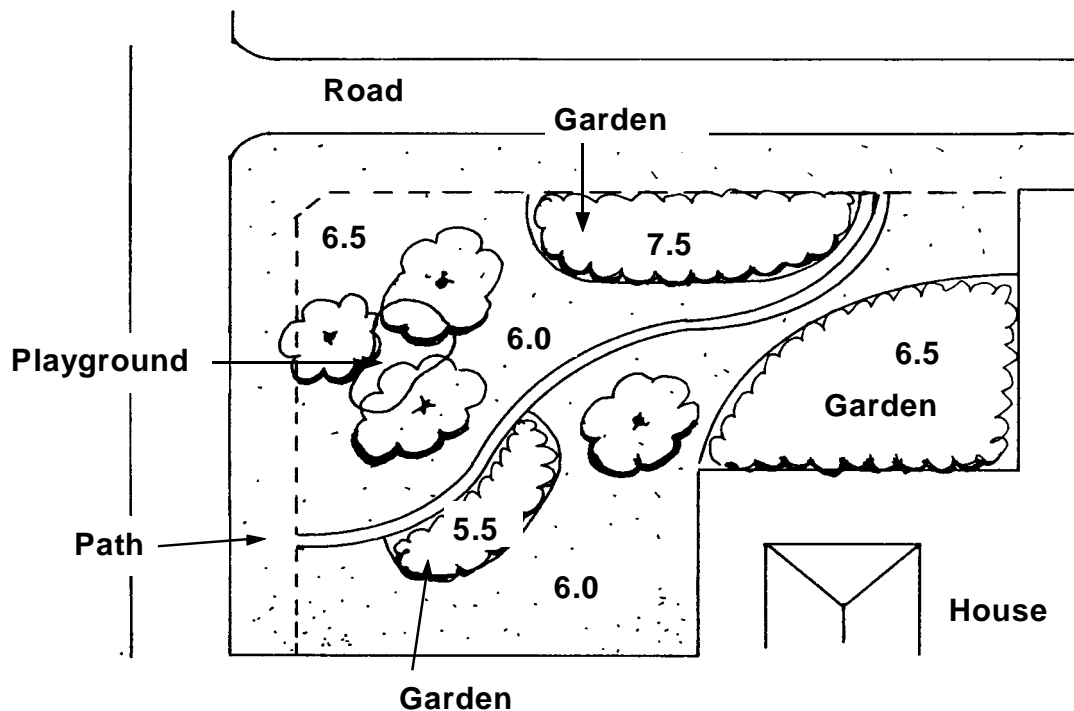

- Fertiliser will be wasted if the pH is not related to the plant species.
- Fertilisers will lock up in soil and not be available to plants.
- Nutrients can build up excess supplies in soil causing toxicities

↓ *pH test should be taken twice a year in changing areas (eg. annual beds). If areas are established or there are no obvious problems once per year would be adequate*

↓ *New garden beds should be tested for pH once constructed and any adjustments made so the pH suits the proposed plantings.*

- Comprehensive soil tests may be needed in some areas to determine the amounts of nutrients available in the soil. This should only need to be carried out in the Grade 1 areas.

↓ *If comprehensive soil tests are to be taken then an estimated number should be calculated and quotes obtained from soil testing laboratories to obtain the most cost effective supplier based on the higher quantity of tests.*

Altering soil pH

Soil pH can be raised or lowered by the use of lime or sulphur.

Lime to raise pH

Both lime and sulphur will react differently in different soils. The following table will give you an example of the amount of lime required to **increase the pH to around 6 - 7**

General Guidelines for the amount of Dolomite required (grams per 1 sq. metre) to correct varying degrees of soil acidity

Soil pH	Sands and sandy loams	Loams and clays
6.3 - 7.0	0	0
5.8 - 6.2	125g	170g
5.3 - 5.7	250g	375g
4.8 - 5.2	375g	500g
4.0 - 4.7	500g	750g

- In established gardens and turf where the pH requires correction avoid applying more than 250g per 1m² per year until the desired pH is reached. Excessive liming can retard plant and turf growth.
- In new or vacant beds incorporation of the larger quantities listed above is possible because the lime is mixed into the first 200 - 300mm of the soil profile.
- Also only use Dolomite in areas where there is not an excess of Magnesium which is unlikely in most Brisbane soils.
- Recheck in 2-3 months time, test top 100-150mm of soil which is the main plants feeder root zone

Sulphur to lower pH

- pH of 7.5 to 8.4 may be developed in soils that are waterlogged, rarely leached, irrigated with water containing calcium and magnesium, or limed excessively.
- Plants growing in Alkaline soils are more likely to show signs of iron, manganese, copper, zinc, or boron deficiency.
- Changing the type of fertiliser for a set period of time may help reduce pH
- Sulphur can be applied through the use of Elemental Sulphur, Aluminium Sulphate or fertilisers containing sulphur such as Ammonium Sulphate or Iron Sulphate.

The amount of Elemental Sulphur (95%) needed to **lower the pH of soils** at three levels of Alkalinity **to around 6.5**. Application per m²

Original soil pH	Sandy Loam	Clay
7.5	45 - 75g	95 - 125g
8.0	125 - 170g	170 - 250g
8.5	170 - 250g	195 - 250g

Further notes;

- a) Landscape suppliers tend to supply landscape soils with a high percentage of organic matter in it. Depending on quantity used the organic matter will break down and can cause significant subsidence in gardens beds. Gardens should be regularly checked for subsidence and rectified as required.

4 Turf

In order for turf grass species to perform properly they need to be suitable for the purpose for which they are designed, but their performance is impacted on by climatic conditions and maintenance practices. To maintain the health of grassed areas mowing will be varied according to the time of year and prevailing weather conditions.

Climatic conditions can impose harsh growing environment when moisture is limited from natural rainfall or irrigation systems. During prolonged dry periods, supplementary irrigation from town water supplies during off peak periods enables these areas to continue growing and remain resilient, often with a supplementary fertiliser programme.

During periods of drought and harsh water restrictions, turf grass maintenance needs to be handled very carefully. Mowing heights need to be raised as growth of the turf grass will be reduced. There will be a lack of vigour and resilience in the leaf structure due to the reduction in moisture, both from weather conditions and the inability to provide sufficient irrigation from town water supplies. This lack of moisture will restrict the fertiliser programme as most inorganic slow release fertilisers rely on the application of water to break down and release the chemicals required for healthy turf grass growth.

Most campuses have turf/grass areas that have evolved rather than being consciously built to sustain the amount of traffic experienced at a University. Most of the growing environments have porosity, drainage and/or slope problems that impact on the sustainability of turf/grass without additional help and care from Grounds Staff.

- ↓ *Check for any noise restrictions that may impact on works.*
- ↓ *All turf/grassed areas are to be mown so they retain their colour and are free from windrows or piles of clippings. There are to be no intended wheel marks, no scalping or compaction of the grassed areas and no black tyre marks on the surrounding paved areas. The edges are to be neatly trimmed and the area left in a clean and tidy state after each service.*
- ↓ *The type of mower to be used, mowing frequency and effective cutting height will be based on site specific requirements as determined by the Grounds Supervisor. All clippings must be disposed of at each service. Before commencing any mowing activity the site needs to be inspected for any rubbish and debris, which must first be removed. The inspection should also*

identify any in ground sprinkler heads which may be in the raised position and therefore need re-setting before mowing.

All equipment must be maintained in good working order with no oil leaks. All cutting edges shall be kept sharp and all guards and safety equipment supplied or specified by the manufacturer must be installed and used. All machinery moved between campuses must be clean and free of weeds and seeds to prevent infection or cross contamination.

↓ *Edging and trimming to be carried out prior to mowing. All trimming or edging needs to ensure clean, straight edges that are not torn, ragged or scalped. There is to be no girdling or bark damage to any tree or shrub from trimming or mowing operations. A tree protection zone (sprayed and/or mulched) should be maintained around all trees. All debris is to be blown off paths and hard surfaces immediately after mowing. No debris should be allowed to enter storm water channels.*

The direction of the mowing will be chosen to avoid distributing cut grass over any paths, access ways, roads, paved areas or mulched areas. Any debris distributed on these surfaces or into drains, gutters, channels, kerbs, metal grates or the like must be removed.

The major turf species found in QUT are as follows

Carpet grass	Green Couch
Greenlees Park	Kikuyu
Queensland Blue Couch	Winter Green
Buffalo	

Suitability of other species will be assessed from site specific requirements.

The mowers used to maintain those species listed are:

Reel mowers (Push and ride on type)
Rotary mowers (Push and ride on type)
Tractor/slasher

Cutting Heights

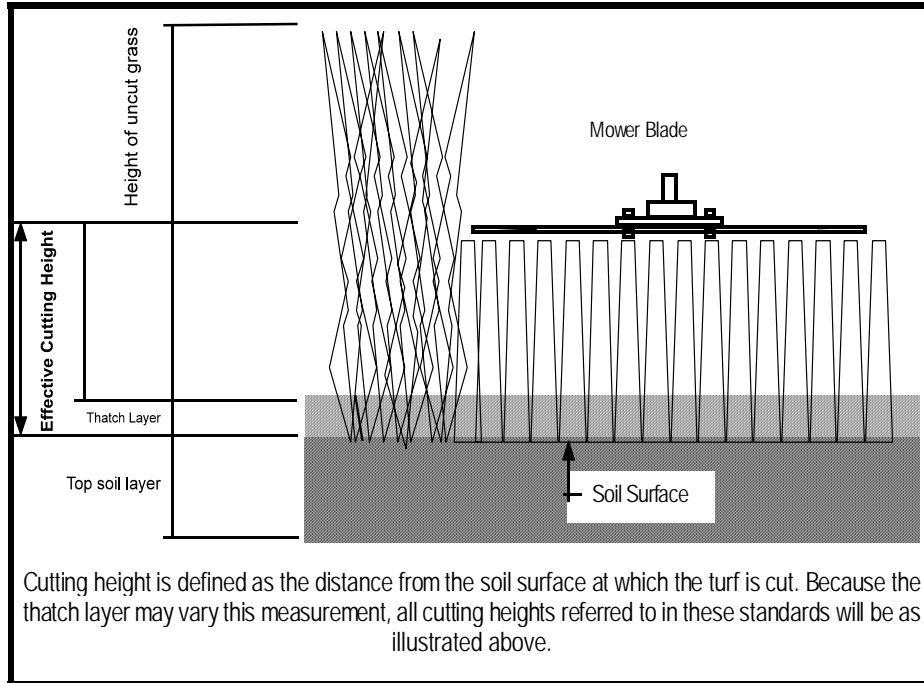

Diagram illustrating the effective cutting height

- General guide to cutting heights used.

Cutting Method	Summer	Winter
<i>Cylinder Mowers</i>	25 - 35mm	30 - 40mm
<i>Rotary mowers</i>	25 - 35mm	30 - 40mm

- Mowing patterns should be set up so grass clippings are dispersed away for gardens and hard surfaces when using mowers without grass catchers.

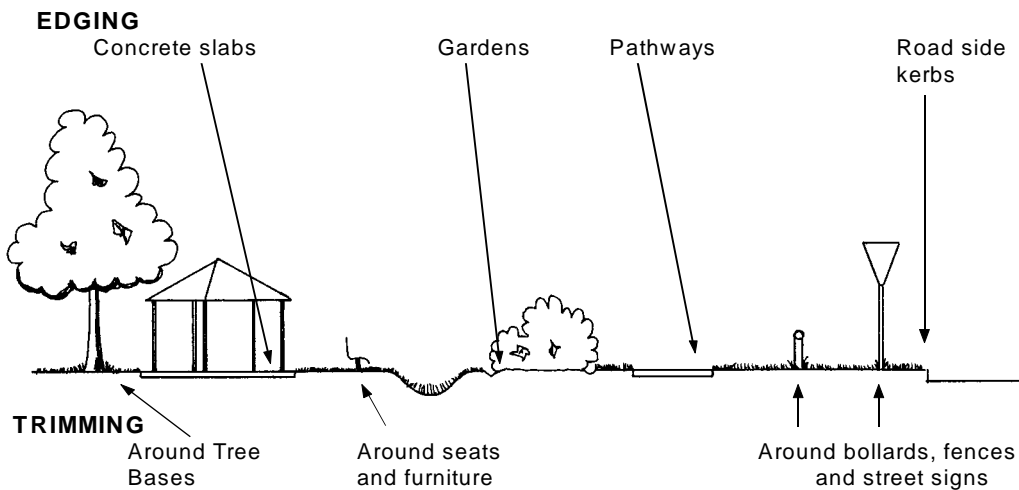

Diagram illustrating the range of Edging and Trimming areas in a site

Turf Grades

The turf grades have been divided into 3 categories.

Level 1 - High profile lawn areas (including the Oval)

Level 2 - Medium profile lawn areas (majority of Campus Lawns)

Level 3 - Bush/environmental areas

The details that make up these levels are as follows

Level 1 - High Profile Lawns

Primary Grass Species	Common Couch Buffalo Qld Blue Couch Winter Green
↓ Inspection	Before commencing any mowing activity the site needs to be inspected for any rubbish and debris, which must be removed. The inspection should also identify any in ground sprinkler heads which may be in the raised position and therefore need re-setting before mowing.
Mowing Frequency	Weekly during the growth season, fortnightly/three weekly during dormancy or as determined by the Grounds Supervisor.
Mower Type	Cylinder or quality rotary mower
Height of uncut grass	Grass allowed to grow to 30-40mm
↓ Effective Cutting Height	Grass cut to 25-35mm
↓ Grass clippings	All clippings to be collected and disposed of at each service.
Fertiliser	A fertiliser program will be determined by the Grounds Supervisor and carried out by staff/contractors as directed generally up to 3 times per year.
Irrigation	Inspect, repair and test using stored or town water, in accordance with current QLD. Water Commission guidelines
Pest and disease	Control symptomatically as identified
Weed Control	Monitor all lawns per service for weed growth and assess if weed control is needed. Turf weed control programs will be determined by consultation with the Grounds Supervisor.
Edging and trimming	Edging and trimming carried out at each service using a mechanical edger (eg. brush cutter or metal blade motorized edger)
Renovations	Cored or sliced on as needs basis as determined by the Grounds Supervisor

Level 2 - Medium Profile Lawn

Primary Grass Species	Common Couch Carpet grass Qld Blue Couch Greenlees Park
↓ Inspection	Before commencing any mowing activity the site needs to be inspected for any rubbish and debris, which must be removed. The inspection should also identify any in ground sprinkler heads which may be in the raised position and therefore need re-setting before mowing.
Mowing Frequency	Weekly during the growth season, fortnightly/three weekly during dormancy or as determined by the Grounds Supervisor.
Mower Type	Quality rotary mower
Height of uncut grass	Grass allowed to grow to 50-60mm
↓ Effective Cutting Height	Grass cut to 35-40mm
↓ Grass clippings	All clippings to be collected and disposed of at each service.
Fertiliser	A fertiliser program will be determined by the Grounds Supervisor and carried out by staff/contractors as directed generally 1-2 times per year
Irrigation	Inspect, repair and test using stored or town water, in accordance with current QLD. Water Commission guidelines
Pest and disease control	Control symptomatically as identified
Weed control	Monitor all lawns per service for weed growth and assess if weed control is needed. Turf weed control programs will be determined by consultation with the Grounds Supervisor and carried out as directed.
Edging and trimming	Edging and trimming carried out at each service using a mechanical edger (eg. brush cutter or metal blade motorized edger)
Renovations	Cored or sliced on as needs basis as determined by the Grounds Supervisor

Level 3 – Bush or environmental areas

All grass within 10meters of roadways, car parks, buildings or access paths not identified as primary or secondary areas, must be maintained at a height not less than 75mm and not more than 150mm. Building perimeters should be sprayed with a non residual, non selective herbicide to a depth not exceeding 100mm. All other areas are to be left as natural vegetation. All fallen branches and storm debris should be cleared from access ways as soon as practical.

All hard surfaces should be inspected on an ongoing basis for any hazards or damage caused by trees, vandalism, vehicles or graffiti and any identified problems should be reported to the Foreperson or the Facilities Help Desk for appropriate action.

Primary Grass Species	Native grass species Common Couch
Mowing Frequency	As determined by the Grounds Supervisor
Mower Type	Brush cutters and tractor/slasher
Height of uncut grass	As determined by the Grounds Supervisor
Effective Cutting Height	NA
Grass clippings removed	NA
Fertiliser	NA
Irrigation	NA
Pest and disease control	NA
Weed control	Leave primary grass species and remove other identified weeds by physical removal or herbicide application in consultation with the Grounds Supervisor
Edging and trimming	Edging and trimming carried out at each service using a mechanical edger (eg. brush cutter or metal blade motorized edger)
Renovations	NA

Fertilisers

Turf Fertilisers and their application

It is planned that two (2) main grades of fertiliser are to be used on the turf in various areas.

As a general guide the following table outlines the annual fertiliser input requirements for turf grass grown under different management conditions.

Situation	g/1m ² /year		
	Nitrogen (N)	Phosphorus (P)	Potassium (K)
Low Maintenance	10g	1g	10g
High Maintenance	20g	2g	15g
Intensive Maintenance	30g	3g	20g

- The decision of which fertiliser to use in which areas will be made by the Grounds Supervisor. It is envisaged that the top grade fertilisers will be applied to the top grade lawns. The table below outlines the different fertiliser options and recommended quantities to be applied
- Many recommendations of fertilisers or hand books talk about the amount N or P or K that should be applied per application or per year.
- If a fertiliser contains N : P : K of 10.1 : 3.3 : 9.5, and we need to apply 5g of N (Nitrogen) per m² then we use the following calculation;

$$1\text{kg} = 1000\text{g}$$

$$10.1\% = 101\text{g}$$

$$1\text{g N} = 9.9\text{g of fertiliser (i.e. } 1000 \div 101)$$

$$5\text{g N therefore} = 49.5\text{g of fertiliser (i.e. } 9.9 \times 5)$$

Turf Grade	Fertiliser Class 1	Fertiliser Class 2
Grade 1	Use a slow release fertilizer (3-4 month release) with a recommended N:P:K of 22 : 1.6 : 12 in Sep/Oct and Dec/Jan In Apr apply 15 : 0 : 19	
Grade 2		Using a slow release fertiliser (3-4 month release) with a recommended N:P:K of 10.1 : 3.3 : 9.5 Applied Sep/Oct, Dec/Jan and Mar/Apr
Grade 3	None Applied	None Applied

Fertiliser Spreader Calibration

- Calibration of spreaders can be done with a large sheet of plastic or canvas minimum size 10m² or an area of concrete the same size but with access to drive over the area.
 1. Place the plastic out on level even ground.
 2. Fill the spreader with the fertiliser to be used.
 3. Set the spreader at the lowest setting.
 4. Start spreading fertiliser at least 5m in front of the plastic and travel over the plastic at the rate at which you would spread on the ground.
 5. Once completely over the plastic stop the spreader.
 6. Carefully pick up the plastic and without loosing any of the fertiliser on it. Bring the fertiliser to a central point on the plastic and then into a container.
 7. Weigh the fertiliser taking into account the weight of the container.
 8. Record the weight.
 9. Repeat this for each of the settings on the spreader and for the different types of fertiliser being used.

This will give a reasonably accurate measurement of fertiliser applied in 10m² which can be multiplied out for set areas.

Fertiliser Application

- Proper application is vital to the success of any fertiliser. With the amount of fertiliser calculated and the fertiliser spreader calibrated, follow the steps below to fertilise a set area.

1. Stand the spreader on a hard surface ready for filling. Never fill the spreader on the lawn area in case of spillage.
2. Fill the spreader with the required amount of fertiliser.
3. Set the spreader at the appropriate setting that will allow the fertiliser to be spread at half the recommended rate.
4. Determine the best way to travel over the lawn so 2 passes can be made at right angle to each other as per the diagram below.
5. Proceed to fertilise the lawn
6. Within 30 minutes of fertilising remove any fertiliser from the paths, paving or hard surfaces and water the area of lawn for 15 to 20 minutes so as to apply a minimum of 10mm of water.

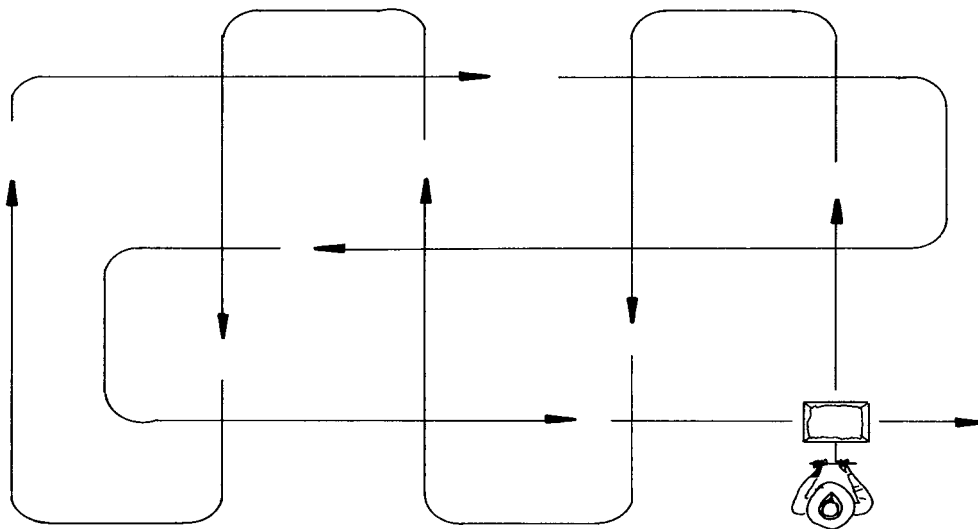

This diagram illustrates the best practice of fertilising with a spreader. Ensure the passes are close enough to achieve the proper overlap of fertiliser to avoid striping.

Weed, Pest and Disease Control

Pests and diseases should be controlled once their population becomes detrimental to the health and/or appearance of the turf grass. This control should take place prior to the pest or disease creating a visual deterioration to the turf.

Most turf grass injury from insect pests and diseases can be prevented by regular inspections of lawn areas and immediate, remedial action. Insects and diseases may cause disorders such as die-back, stunting or distortions of growth, browning, yellowing, or bleaching of leaves. Early detection of such symptoms may prevent the rapid buildup of insect populations, which can occur when conditions are favorable. Some insects feed only at night, and

unless a special effort is made to look for them, they may go undetected for a long time.

- ↓ *Most weed/pest control is to be carried out using knapsacks and hand held sprayers. A motorised unit it is only to be used by personnel with Commercial Operators Licence. All herbicide spraying must be carried out in accordance with the ACDC Act and recorded on the appropriate forms.*
- ↓ *All spraying operations are to be suspended whilst pedestrians are in close proximity to any work. Spraying of weeds must be carried out with due regard to protecting surrounding plant species.*
- ↓ *No ground distribution of herbicides shall be carried out under weather conditions which might reasonably be expected to result in damage or injury to any persons or vegetation not intended (i.e. contamination by over spraying, drift or increased absorption into soil or waterways through adverse conditions). All desired trees, shrubs and ground cover plants shall be protected from contamination at all times.*
- ↓ *Ensure irrigation is turned off so the area will not be irrigated for at least 8 hours after spraying unless required by the manufacturer of the chemical*
- ↓ *All Level 1 and 2 lawns will have as many weed species controlled in them as is practical*

- **Legal Requirement**

All pesticides, including insecticides, fungicides and herbicides utilized on sites shall be for uses as registered with the Department of Primary Industries or other relevant statutory Authorities and as specified on the manufacturers Product Label.

↓ **Storage**

PROTECTION: All chemicals shall be stored in original labeled containers, secured against accidental damage, leakage or spillage. A label must be displayed and be fully legible on each individual container.

All chemicals shall be kept in a locked cabinet at the main compound and while being carried in vehicles. The cabinet shall be constructed in such a manner that each individual container is secured against accidental damage, leakage, spillage or access by children or unauthorized personnel. The cabinet shall be clearly identified as containing potentially hazardous chemicals. The cabinet shall be kept clean at all times and shall also contain appropriate safety equipment for handling chemicals. No food or fertilisers should be stored near the chemicals.

Safety Equipment

USE: Safety Equipment for the mixing, application and disposal of all chemicals shall be correctly worn and utilized by personnel during all chemical handling operations on site.

Safety equipment shall be kept clean and free of chemical residue and be maintained in a safe, serviceable manner at all times.

EQUIPMENT REQUIREMENTS: The minimum safety equipment to be available on-site to each person handling chemicals shall comprise of the following:-

- 1 x Waterproof Coveralls
- 1 x Safety Goggles
- 1 x Gumboots
- 1 x Waterproof Rubber Gloves (or disposable waterproof gloves)
- 1 x Pesticides Respirator with detachable filter cartridge
- 2 x Spare Clean Filter Cartridge

↓ Record all chemical usage including details of pesticides used, rates of application, date of application and method of application. All records should be available as requested.

5 Gardens

Garden Categories

All gardens and landscape areas can be broken into 3 main categories.

- Level G1 - High Profile Gardens
- Level G2 - Medium Profile Gardens
- Level G3 - Bush or screen planting

The details of these areas are as follows:

Level G1 – High Profile Gardens

Description	These gardens may include hedging, formal or semi formal planting. More conspicuous, aesthetically pleasing landscaped areas, requiring high levels of maintenance, often used as entry statements and functional areas.
Primary Plant Species	Combination of Natives and Exotics
Primary Mulch	1" hoop or other decorative mulch as determined by the Grounds Supervisor. No fines and a minimum 75mm thick. Forest blend will be considered for use in areas where excess leaf litter is present. All mulching operations carried out by external providers should be authorised by the Grounds Foreperson prior to taking place. Mulch must be kept clear of all plant stems and should be maintained at the same level as any surrounding hard surface. All hard surfaces should be thoroughly cleaned after mulching operations.
Irrigation	Some newer areas have automatic systems. Inspect, repair and test in consultation with Grounds Supervisor, using stored or town water in accordance with current Qld. Water Commission guidelines.
↓ Inspection and service frequency	Inspect all gardens per weekly service. Any displaced mulch should be reinstated into garden beds and the area left clean and tidy at all times. Gardens should be regularly checked for subsidence and rectified as required. Any needles or sharps should be reported to the Grounds Supervisor for appropriate action.

↓ Rubbish removal	Collect and remove any rubbish and debris at the start of each day and as seen for the remainder of the day
Pest and Disease Control	Treat symptomatically as identified
↓ Pruning	<p>Minor pruning work should be carried out on a per service basis to maintain desired shapes and keep access ways clear. Any outgrowths that could impede pedestrian movement or create a potential hazard to pedestrians or vehicles must receive immediate attention. All debris will be removed from the site each visit. No debris should be allowed to enter storm water channels.</p> <p>Chain saw pruning is to be restricted to plants not more than 4 meters high and should only be carried out from ground level. All other material requiring pruning should be reported to the Grounds Supervisor for further consideration. All pruning is to be carried out in accordance with AS 4373, standard horticultural practices and instructions from the Grounds Supervisor. All pruning equipment must be kept in a sharp and clean condition to reduce the possibility of infection or contamination. All debris should be cleared at the completion of each service and the area left in a clean and tidy state.</p>
↓ Weed Control	All garden areas are to be kept in a predominately weed free state. Physical removal of advanced weeds or herbicide application to smaller or prostrate weeds should be carried out per service. All dead material is to be removed.

Level G2 - Medium Profile Gardens

Description	These gardens will be made up of the older, less conspicuous landscape areas, designed to enhance building surrounds but not generally used as functional areas. They may include areas that are to be upgraded as part of the master plan, or areas that will be demolished for new buildings.
Primary Plant Species	Combination of Natives and Exotics.
Primary Mulch	Clean forest blend (no palm crowns, no tub grindings) or other decorative mulch as determined by the Grounds Supervisor. No fines and a minimum 75mm. All mulching operations carried out by external providers should be authorised by the Grounds Supervisor prior to taking place. Mulch must be kept clear of all plant stems and should be maintained at the same level as any surrounding hard surface. All hard surfaces should be thoroughly cleaned after mulching operations.
Irrigation	Manual systems may exist otherwise by hose and sprinkler combinations as necessary during establishment. Inspect, repair and test in consultation with Grounds Supervisor, using stored or town water in accordance with current Qld. Water Commission guidelines.
↕ Service Frequency	Inspect all gardens per fortnightly service. Any displaced mulch should be reinstated into garden beds and the area left clean and tidy at all times. Gardens should be regularly checked for subsidence and rectified as required. Any needles or sharps should be reported to the Grounds Supervisor for appropriate action.
↕ Rubbish removal	Collect and remove any rubbish and debris at the start of each day and as seen for the remainder of the day

Pest and Disease Control	Treat symptomatically as identified
<p>↴ Trimming/Pruning</p>	<p>Minor pruning work should be carried out on a per service basis to maintain desired shapes and keep access ways clear. Any outgrowths that could impede pedestrian movement or create a potential hazard to pedestrians or vehicles must receive immediate attention. All debris will be removed from the site each visit. No debris should be allowed to enter storm water channels.</p> <p>Chain saw pruning is to be restricted to plants not more than 4 meters high and should only be carried out from ground level. All other material requiring pruning should be reported to the Grounds Supervisor for further consideration. All pruning is to be carried out in accordance with AS 4373, standard horticultural practices and instructions from the Grounds Supervisor. All pruning equipment must be kept in a sharp and clean condition to reduce the possibility of infection or contamination. All debris should be cleared from hard surfaces at the completion of each service and the area left in a clean and tidy state.</p>
<p>↴ Weed Control</p>	<p>All garden areas are to be kept in a predominately weed free state. Physical removal of advanced weeds or herbicide application to smaller or prostrate weeds should be carried out per service. All dead material is to be removed.</p>

Level G3 - Bush or Environmental areas

All fallen branches and storm debris should be cleared from access ways as soon as practical.

All hard surfaces should be inspected on an ongoing basis for any hazards or damage caused by trees, vandalism, vehicles or graffiti and any identified problems should be reported to the Foreperson or the Facilities Help Desk for appropriate action.

Description	These areas are made up of undisturbed bush or screen plantings around the perimeter of Campus.
Primary Plant Species	Natives
Primary Mulch	No formal mulching. Natural leaf fall from trees and shrubs or as determined by the Grounds Supervisor.
Irrigation	No irrigation
↓ Service Frequency	These areas are fully inspected on a monthly basis or as requested.
↓ Rubbish removal	Removed as seen.
Pest and Disease Control	No control measures used.
Trimming/Pruning	Pruning may only be carried out to remove dead or damaged plant material or as otherwise deemed a hazard
Primary Weed Control Method	Physical removal or herbicide treatment as identified with Grounds Supervisor

Garden Fertilisers and their Application

Fertilisers will be added to the gardens in 5 main types which are listed below as a minimum standard of analysis.

Type 1	General Fertiliser N:P:K 10.1 :3.3 : 9.5 + trace elements (Growforce 201 or the like)
Type 2	A quality mixed fertiliser with an N:P:K of 12.2 : 4.9 : 13.5 + trace elements (Growforce 509 or the like)
Type 3	A quality slow release fertiliser with an N:P:K of 11.8 : 5.2 : 14.2 with trace elements (Growforce Rustica Blue or the like)
Type 4	Organic Fertiliser with N:P:K 4:3:2 (Terra Firma Organic Life or the like)
Type 5	Liquid fertiliser with an N:P:K of 13.7 : 4.6 : 22.5 + trace elements (Growforce GF 9 or the like)

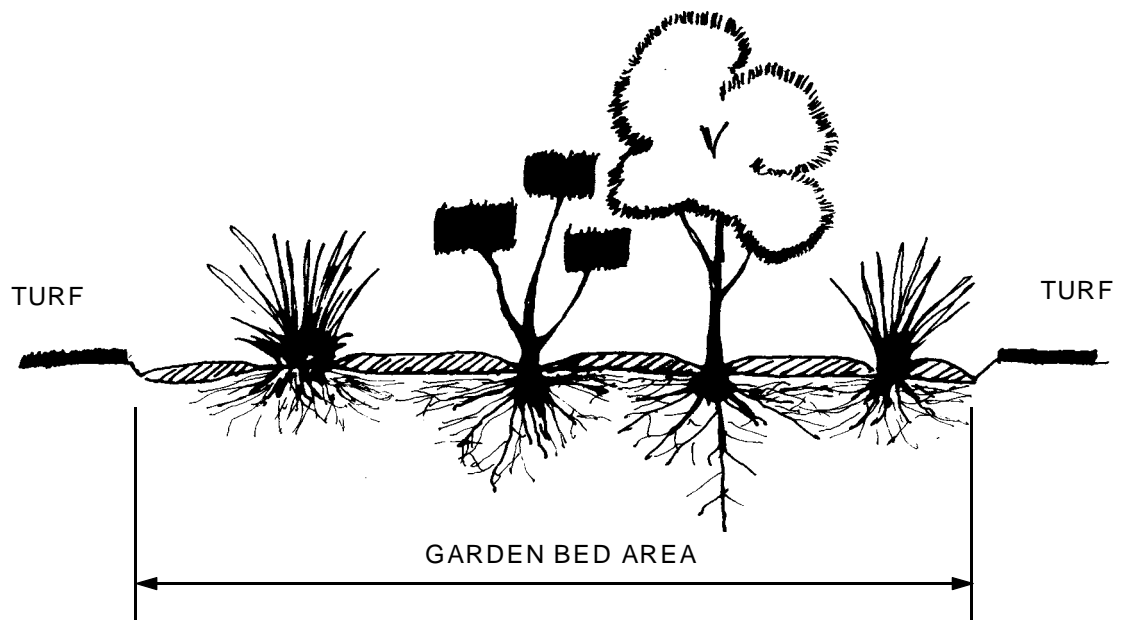

Spread fertilisers evenly over the the entire garden bed area not just around the base of the plants. This supplies nutrients to all the feeder roots.

The table below lists the plants and the most suitable fertiliser, application rate and frequency. This is a general guide and is a minimum standard. Other specific fertilisers for specific plant species could be used if desired.

Plant Species	Fertiliser type	Application rate	Frequency of application
Azaleas	3 & 4	3=40 grams per m ² 4=100 grams per m ²	4 times (Sep, Nov, Jan, Mar)
Gardenias	1 & 5	1=30 grams per m ² 5=10 grams per litre	3 times (Sep, Dec, Mar)
Hibiscus	3 & 4	3=40 grams per m ² 4=100 grams per m ²	5 times (Aug, Oct, Dec, Jan, Mar)
Palms	3 & 4	3=100 grams per metre of height 4=200 grams per metre of height	3 times (Sep, Dec, Mar)
General non native plantings	2	40 grams per m ²	2 times (Sep, Feb)
Native plantings	1 & 4	1=40 grams per m ² 4=100 grams per m ²	2 times (Sep, Feb)
Annuals	2 & 5	1=30 grams per m ² 5=2 grams per litre	Prior to each planting

pH

Maintain the soil pH between 6.0 and 7.0 with an optimum of 6.5

Soil testing

Soil testing will be done as directed by the Grounds Supervisor. Each test will be representative of the area and submitted to a registered NATA Laboratory for a complete analysis.

Correction of any deficiencies will be carried out in accordance with the test results.

Tests may be required to identify biological problems relating to plant growth.

Mulching Gardens

↓ Mulching of gardens will be carried out as per the following diagram

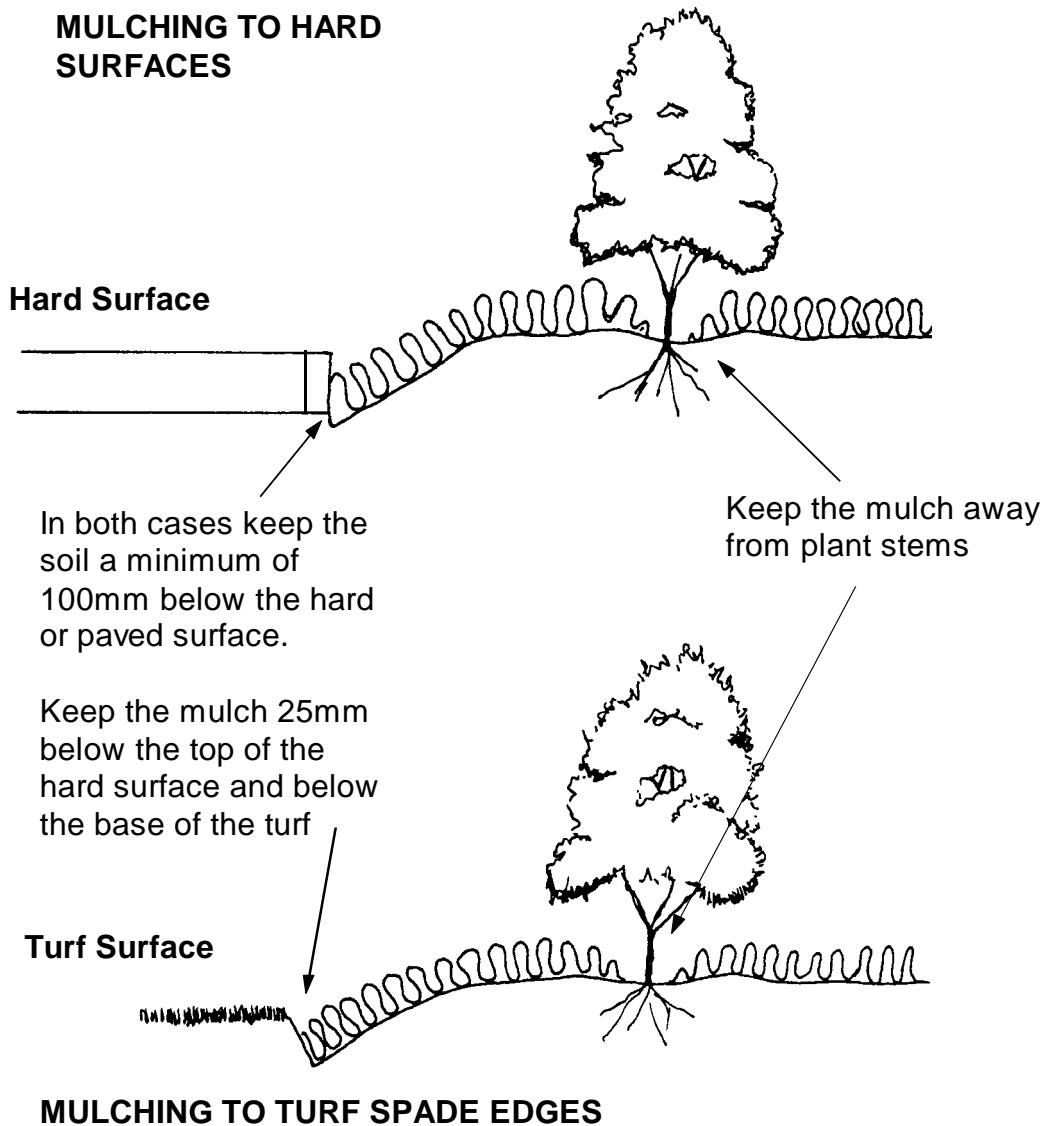

Planting Details

Dig hole twice the depth and twice the width of the rootball

When planting in dry conditions fill planting hole with water and allow to drain away before planting

If imported soil is to be used in the planting hole mix a maximum of 50% new soil with existing site soil.

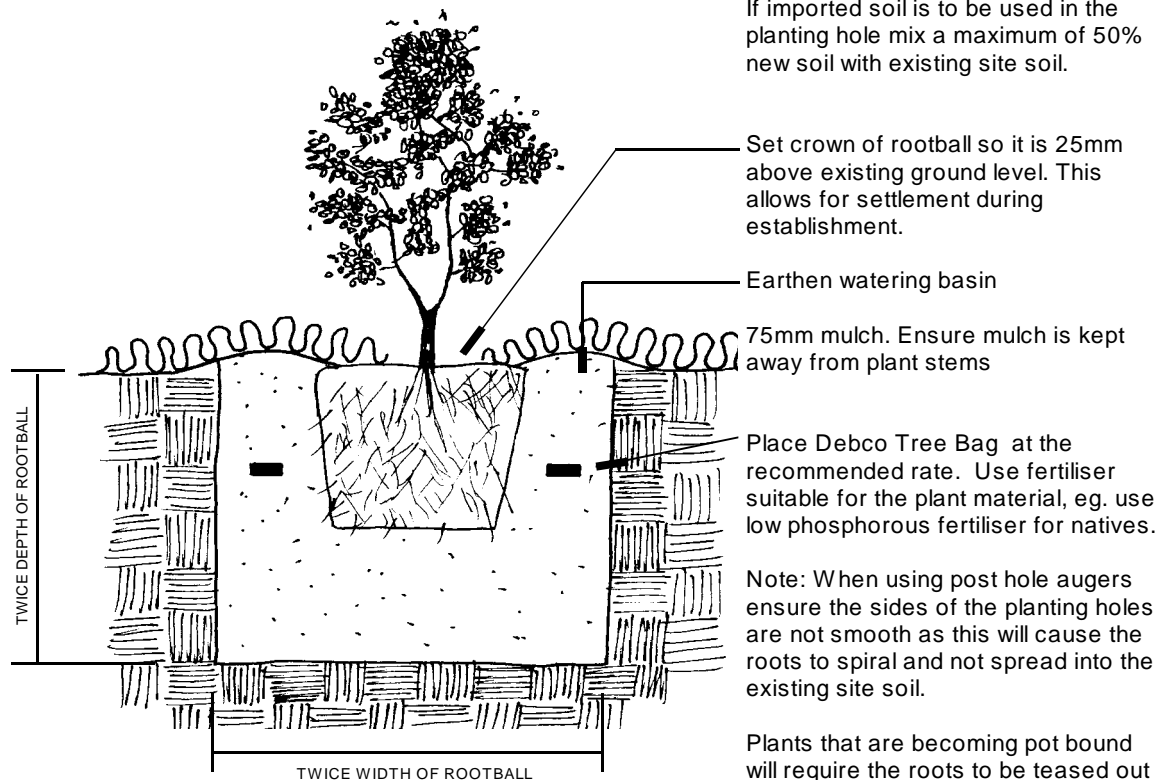

Set crown of rootball so it is 25mm above existing ground level. This allows for settlement during establishment.

Earthen watering basin

75mm mulch. Ensure mulch is kept away from plant stems

Place Debco Tree Bag at the recommended rate. Use fertiliser suitable for the plant material, eg. use low phosphorous fertiliser for natives.

Note: When using post hole augers ensure the sides of the planting holes are not smooth as this will cause the roots to spiral and not spread into the existing site soil.

Plants that are becoming pot bound will require the roots to be teased out and or sliced. Slice roots by running a sharp knife up the outside of the root ball at 4 equal intervals around the rootball. Do not insert the knife more than 10mm into the root ball. Any roots that may be spiraling around the base of the pot should be removed with sharp secateurs.

Once planted apply at least 5 litres of water per plant.

Planting Detail

Pruning Shrubs

REMOVING FINISHED FLOWER STALKS

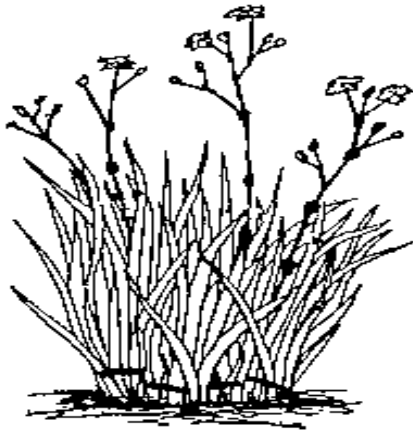

YES

Remove flower stalks that are finished blooming; remove damaged, yellowing or dead leaves to ground level.

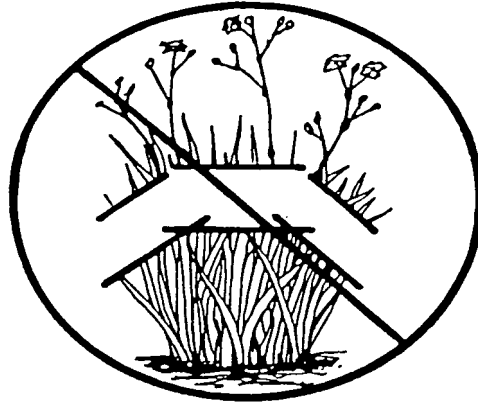

NO

Do not cut leaves unless they are damaged

PRUNING SHRUBS TO NATURAL SHAPE

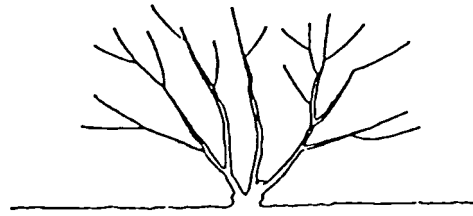
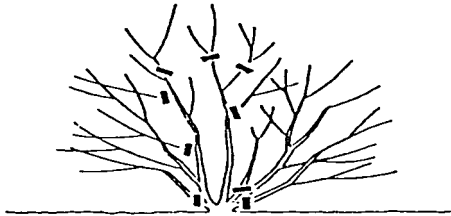

BEFORE

Selectively thin out branches to reduce bulk of plant once the desired size and form is reached.



AFTER

Shrub should maintain its natural form and shape.

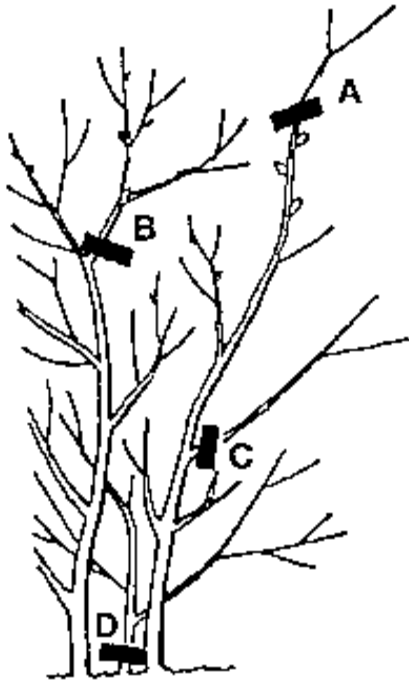

Suggestion to location of pruning cuts

- A) Above a healthy outward facing bud.
- B) Above a healthy strong outward facing branch.
- C) Back to a main or primary branch.
- D) To ground level if removing suckers or water shoots.

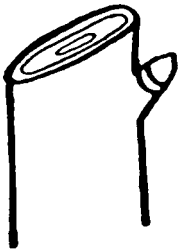

YES

Make cuts just above live outward facing bud at slight angle

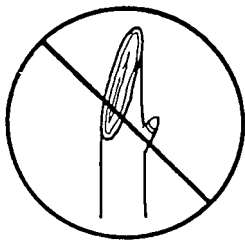

NO

Do not cut below the bud or at a severe angle

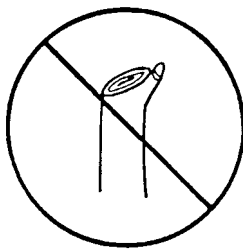

NO

Do not cut too closely to the bud or below the bud

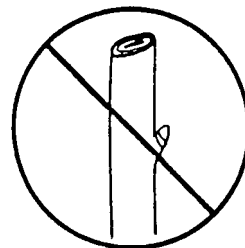

NO

Do not leave a stub

Cut Locations and Types



BEFORE

Prune by the lateral bud that will produce the branch you want - the bud points direction of the new growth. Select an outward facing bud.

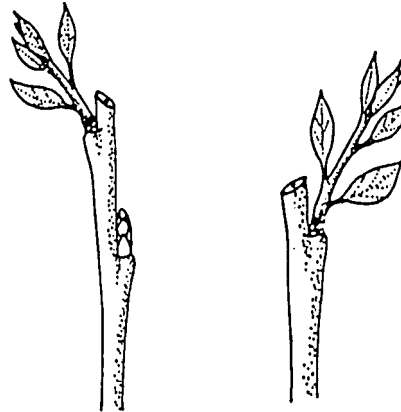

AFTER

The new branch will grow out from the trunk, rather than criss-crossing with other branches inside the foliage.



YES

Selectively cut back leggy growth to maintain desired height

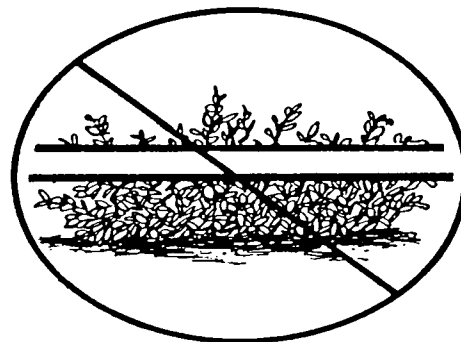

NO

Do not shear ground covers to control growth

Shoot Direction and Groundcover Treatment

Transplanting Shrubs



Prune the shrub. Remove a maximum of 50% of the existing foliage and tie up if necessary

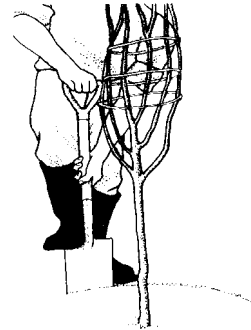

Cut a vertical slit around the shrub 300 - 400mm out from the stem.



Take out a trench of soil 300mm wide of soil on the outside of the slit. Prune any roots that protrude into the trench



Work the spade under the rootball at 45 degree angle. When the plant is free carefully rap with hessian



Dig the hole in the new site as per the planting detail. Add some blood and bone or other suitable the base of the hole and mix with planting soil.



Carefully place the plant into the hole. Ensure the top of the rootball is 25mm higher than the surrounding ground level fertilisers to Create a small berm around the plant to retain water. Add a minimum of 5lt of water and then mulch. Stake if required.

6 Trees

Mulching Trees

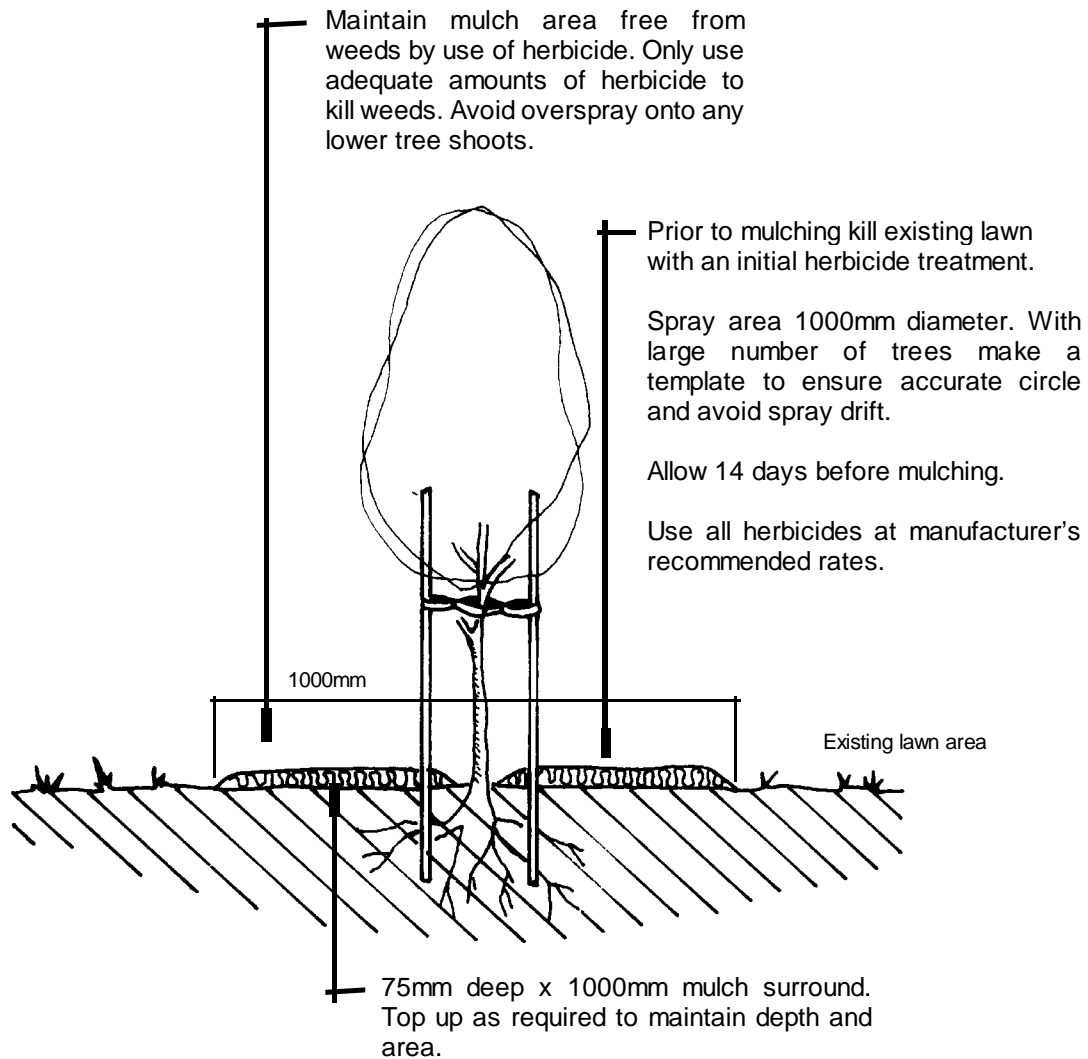

- ↓ *Newly planted trees in 200mm - 45lt pot size should have a mulched protection zone of at least 1 meter in diameter around their base*
- ↓ *Established trees should have a mulched protection zone of at least 2 meters in diameter around their base.*
- ↓ *Mature trees should have a mulched or sprayed protection zone as large as possible around the root zone considerate of the use of the area under the canopy but at least 3 meters in diameter*

General Maintenance

Aeration around some tree species in areas may be required as a result of compaction, poor soil air porosity, or waterlogging. The primary cause of the poorly aerated soil needs to be identified and if possible corrected. Aeration should be carried out with high pressure soil aeration equipment. This task is best carried out by experienced operators. Parking of vehicles within the trees drip line must not be permitted.

Fertilising Trees

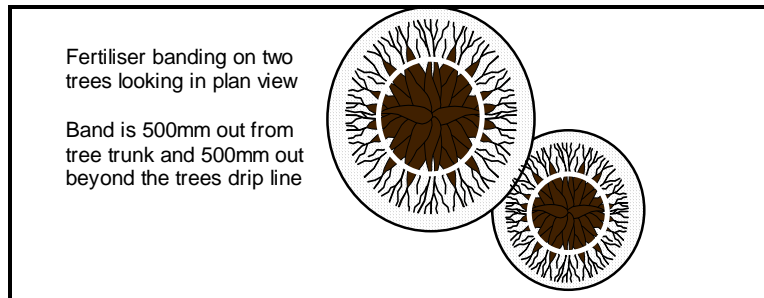

Staking Trees

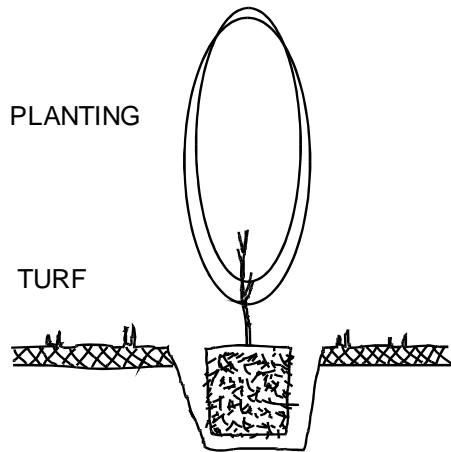

Position plant in planting hole that has been dug 30% larger than the pot size of the tree. When digging holes with an auger ensure sides of the hole are not glazed. On dry sites fill hole with water and allow to drain before planting. Use a sharp knife to slice up the side of the root ball at 4 equal intervals around the root ball. Do not insert the knife more than 25mm into rootball

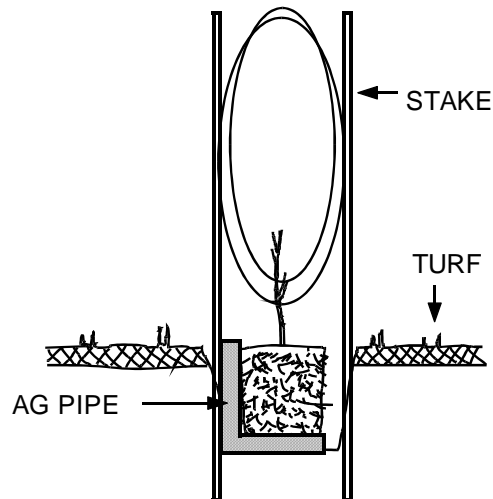

Staking to be carried out prior to back filling the planting hole. Use 50mm x 50mm x 1800 hardwood stakes. Position stakes away from rootball to avoid damage to root system and to minimize rubbing of plant against stakes in winds.

Install 75mm Agricultural pipe down side and around half of the base of the planting hole before back filling hole.

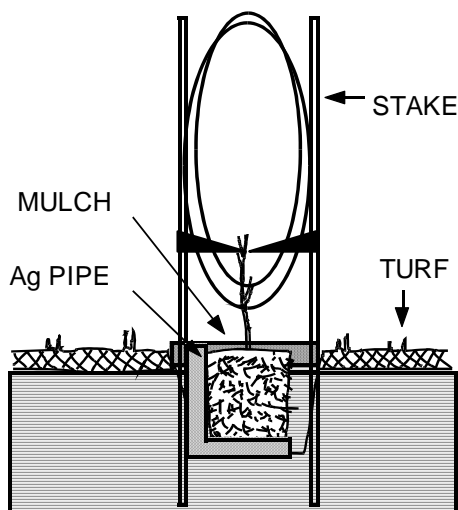

With stakes and pipe in position back fill planting hole. Place Debcos Treebags in top quarter of planting hole. Use at recommended rate/plant size. On sites with poor soil incorporate 50% organic topsoil mix with site soil and firm down. Create a small berm around root ball to contain the water. Water in with minimum of 20 litres of water. Mulch around plant to a diameter of 1000mm. Mulch type to be as specified on drawings at minimum of 75mm deep. Ensure mulch is kept away from stem.

Use hessian tie in figure eight to stabilize tree. Staple tie to stake. Position tie 1/3 up height of tree.

Tree Planting and Staking Detail

(not to scale)

Pruning Trees

All pruning is to be carried out in accordance with AS 4373, standard horticultural practices and instructions from the Grounds Supervisor

REMOVING BRANCH BACK TO ANOTHER BRANCH

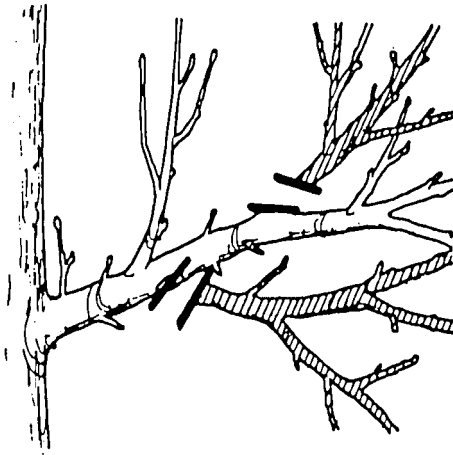

YES

Cut back dead or damaged wood to the nearest live wood branch.

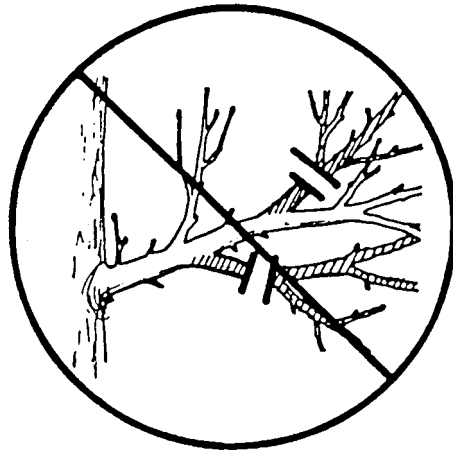

NO

Do not leave stubs of dead wood.

HOW NOT TO REMOVE A BRANCH TO THE TRUNK

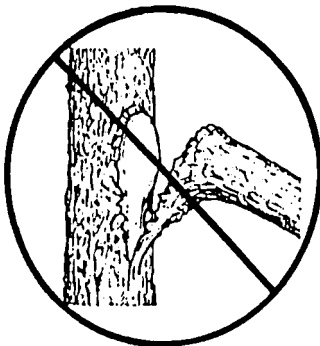

NO

Unless undercut the weight of a heavy branch will tear the bark of the trunk

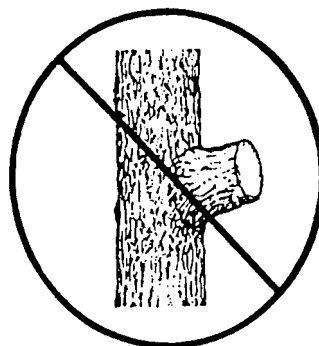

NO

An ugly stub left behind will die back, will become an entry point for disease.

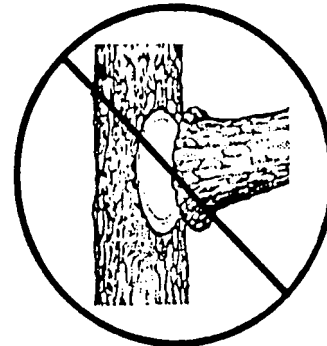

NO

A dangerously large and vulnerable wound results from a cut made too close to the trunk. The tree is unlikely to properly heal.

Tree Pruning - Small Branch Removal

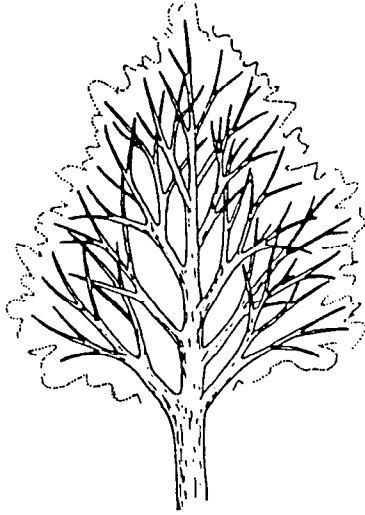

THIS TREE NEEDS PRUNING TO
THIN OUT EXTRA GROWTH

YES

SELECTIVELY REMOVE BRANCHES BACK
TO EXISTING LIMB OR TRUNK; KEEP
NATURAL SHAPE, JUST FEWER BRANCHES

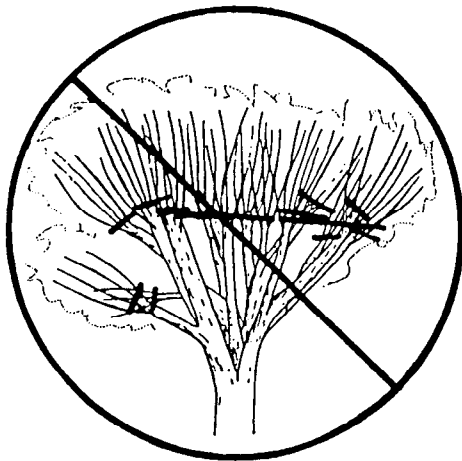
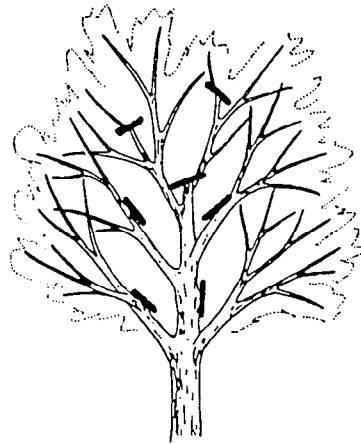

NO

CUTTING BRANCHES LIKE THIS
WILL CAUSE A WORSE PROBLEM
THAN BEFORE

Tree Pruning - Selective Thinning

HOW TO REMOVE A BRANCH TO THE TRUNK

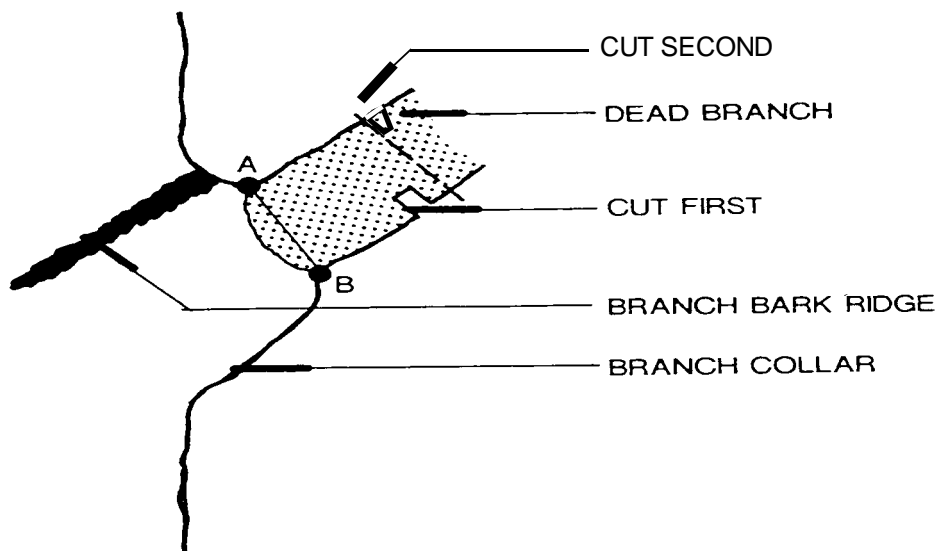
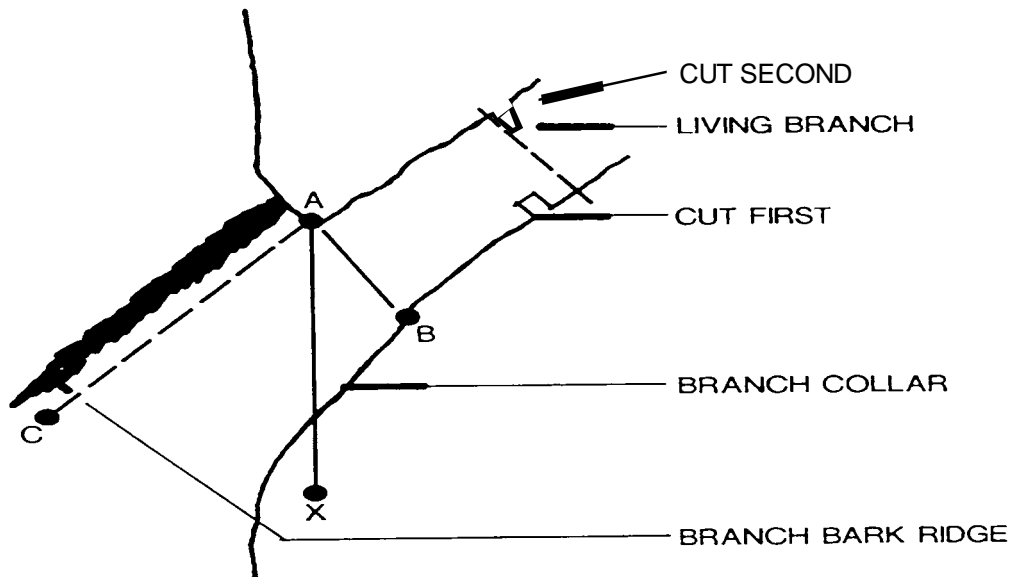

If the branch is long and too thick to cut easily, it should first be cut back to leave a stub of 450mm. If necessary, cut a long, heavy branch into several convenient, manageable lengths to reduce the weight in easy stages.

To remove a branch, the final cut should be made from the outside edge of the branch bark ridge to the bottom of the branch collar (see A-B above). Do not flush cut. Do not leave a stub. Do not paint the cut.

Tree Pruning - Branch Removal

7 Surfaces

Problems may arise with hard surfaces as listed below. Any problems that may create a safety problem should be reported to the Grounds Supervisor or the Facilities help desk for remedial action.

Tree Roots

As trees and palms mature their root systems may affect near by paving. The extent to which they affect the paved area will need to be assessed.

Ants

While ants will not damage the actual paver they tend to burrow in the sub base and bring the material to the surface. If allowed to continue their activities can lead to the pavers subsiding and becoming a trip hazard. Also sand or fine material on the surface of the pavers can create a slip hazard.

Mould / Algae

If this problem arises the initial response should be to identify the cause. It may be shade, excessive moisture, a low spot in the path, or a combination of all these. If left untreated it may become a slip hazard.

Dirt, Grime and Oil Spillages

The surface of pavers is porous and will build up grime and dirt that will not usually come off with sweeping. Spills can also create a slip hazard. All hard surfaces are periodically cleaned by the cleaning department.

Concrete and pavers

↓ Weeds in joints should be sprayed in conjunction with other weed control. Chipped or cracked concrete and pavers may create a trip hazard

Bitumen

Like Concrete and Pavers, Bitumen is relatively low maintenance. The important thing to remember with bitumen is to retain a sealed surface. Water and fuels are the major enemies of bitumen surfaces. Once the surface is broken the moisture quickly gets into the sub-base and breaks up the surface causing possible trip hazards.

↓ Weeds tend to grow in small cracks in bitumen and around its edges. Weeds are to be sprayed in conjunction with other weed control.

8 Rubbish and debris

↓ ***Remove any rubbish and debris from the designated work area on a daily basis.***

Note: Cleaning contractors may be responsible for the removal of rubbish and debris from pathways, roadways, stairs, ramps and courtyards for an initial clean up at the commencement of each day. Grounds staff will then be responsible for the remainder of the day, but the removal of all rubbish from designated garden beds and lawn/grassed areas remains the responsibility of grounds staff at all times (regardless of how it gets there). No rubbish or debris should be allowed to enter storm water channels.

9 Restrictions

Check with the Grounds Supervisor for any restrictions that may impact on works due to pedestrian movements or campus timetabling constraints. All motorised or noisy work must be undertaken between 7.00 am and 8.00 am on week days or designated weekends (as directed by the Grounds Supervisor).